



IntesisBox®

Modbus Server - Honeywell XLS 80

Gateway for integration of Honeywell XLS 80 fire panels into Modbus (RTU and TCP) enabled control systems.

Integrate your Honeywell fire panels into your Modbus master device or system (SCADA, BMS, PLC, HMI, TouchPanels...).

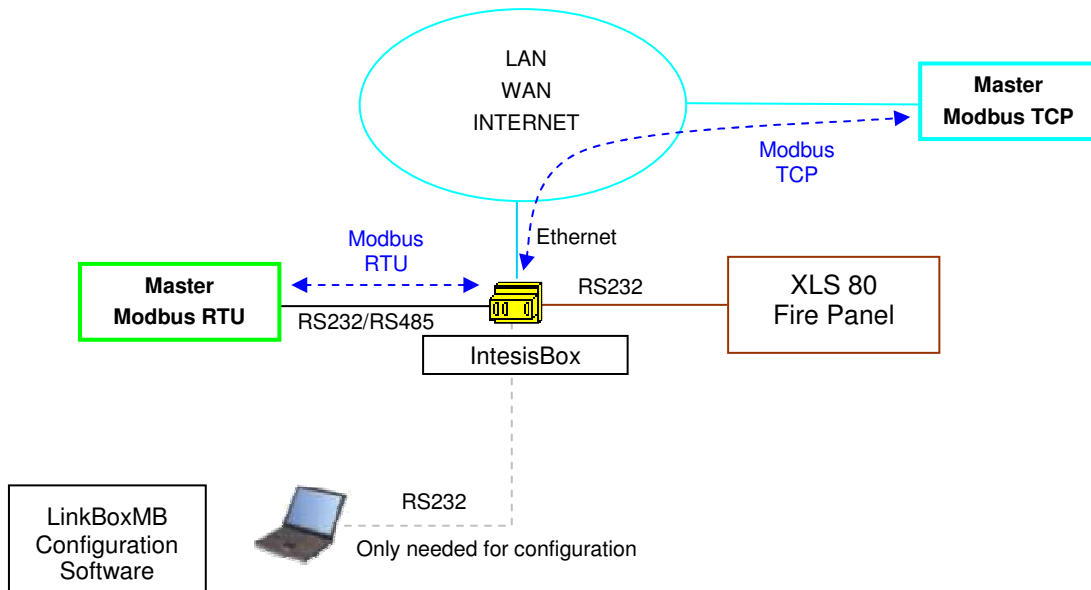

Monitor & Control your network of XLS 80 fire panels remotely from your Control Center using any commercial SCADA or monitoring software with Modbus TCP driver.

IntesisBox allows Modbus TCP (Ethernet) or Modbus RTU (RS232 or RS485) communication, configurable by software. *IntesisBox is a server device in case of Modbus TCP communication, or a slave device in case of Modbus RTU communication.*

IntesisBox connects to the RS232 port of the Honeywell panel, either through the RS232 port of the mother board, or through the isolated ISO-RS232 port (optional card).

Monitoring of the panel elements (detectors, outputs...) through independent Modbus registers. The value in the Modbus register indicating the state of the panel's element is fully configurable. Commands toward the panel are also supported (reset, silence, test elements...).

Fixed Modbus address map, the register number identifies the element into the panel. Simple configuration, no point's configuration needs to be entered, just the communication parameters (IP address, baud rate...). One full panel capacity is supported.

IntesisBox Modbus Server series are configured using *LinkBoxMB*, a software tool for windows™ which is supplied along with the purchase of IntesisBox with no additional cost. *The user interface of LinkBoxMB allows simulating the values of the Modbus registers without the need to be physically connected to the panel, very useful while in commissioning phase.*

Description

IntesisBox Modbus Server for integration of HONEYWELL XLS 80 fire panels	
Order Code	Description
IBOX-MBS-XLS80 	<p>This gateway allows integrating the Honeywell panel through Modbus protocol. The gateway acts as a Modbus slave device. Commands toward the panel are allowed. Immediate response, operation based on events.</p> <p>Main features</p> <ul style="list-style-type: none"> • Software for configuration and test is supplied with the gateway. • Through the user interface, it is allowed to simulate the status of the Modbus registers without the need to be physically connected to the panel. • Allows to be mounted on DIN rail, wall or desktop. • Power from 9 to 30Vdc or 24Vac (Power supply supplied) <p>Modbus features</p> <ul style="list-style-type: none"> • Modbus TCP or • Modbus RTU over RS232 or RS485 selectable. • Parameters configurable: IP address, slave number, baud rate, etc. • Modbus functions supported: 03 & 04 for read, 06 for write. • Every register contains the information of a single element. Registers of 16 bits MSB..LSB. • Fixed Modbus register map, the register number identifies the element. <p>XLS80 features</p> <ul style="list-style-type: none"> • Capacity: 1 to 8 loops (depends on the panel). • Detectors: 1 to 99 per loop (depends on the panel). • Modules: 1 to 99 per loop (depends on the panel). • 1 to 255 zones (depends on the panel). • 15 general states of the panel in independent Modbus registers. • Indication of communication error with the panel. • Supports protocols full/duplex (panel main board) and half/duplex (opto-isolated ISO RS232 board, recommended). • Simple configuration: COM, baud rate, etc. • Each detector, module and zone is offered in an independent Modbus register. • The value offered per each Modbus register, according to each possible state of the element associated, is configurable through a point's relation table. This allows representing different states of the element with a single value in the Modbus register, and even ignoring certain undesired states. • Commands toward the panel are allowed, like reset, silence, etc for the panel and activate/deactivate elements and put them into test mode.

Sample applications

Integration of Honeywell XLS 80 panels into Modbus control systems.

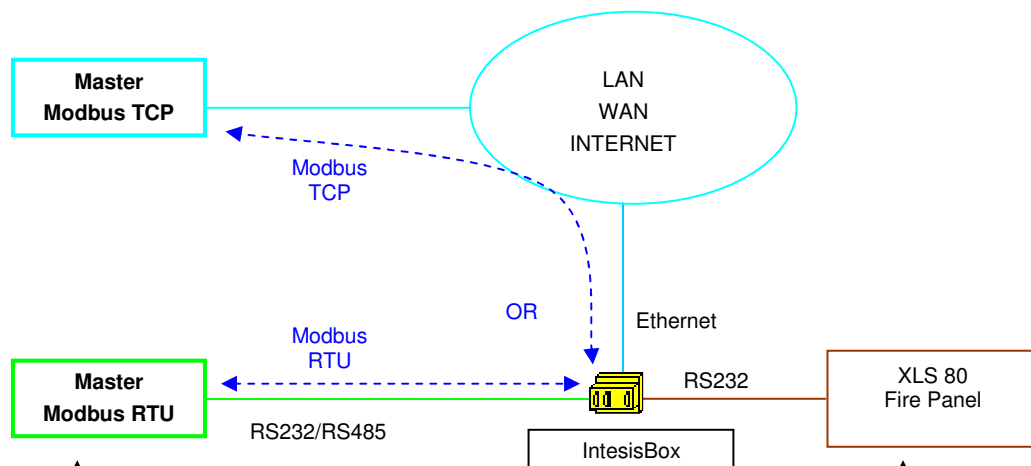

Modbus control system:

- Building Automation.
- SCADA.
- HMI
- TouchPanels
- Programmable Logic Controllers (PLC)
- ...

Honeywell XLS 80 panel:

- Detectors.
- Modules.
- Zones
- ...

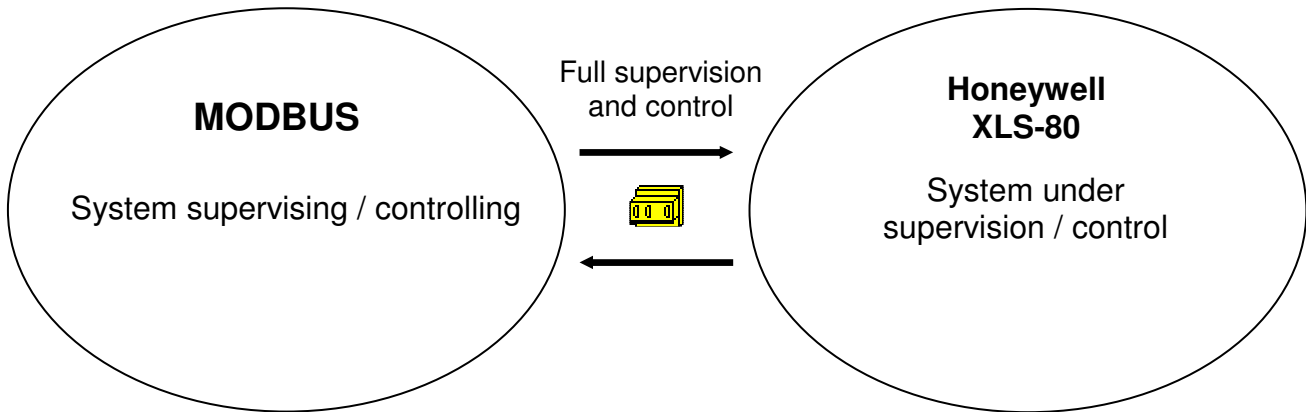

TRADEMARKS: All trademarks and tradenames used in this document are acknowledged to be the copyright of their respective holders. The information in this document may change without preadvise.

Typical application

Monitor & Control of a network of Honeywell XLS 80 fire panels remotely from a Control Center, using any commercial SCADA or monitoring software with Modbus TCP driver.

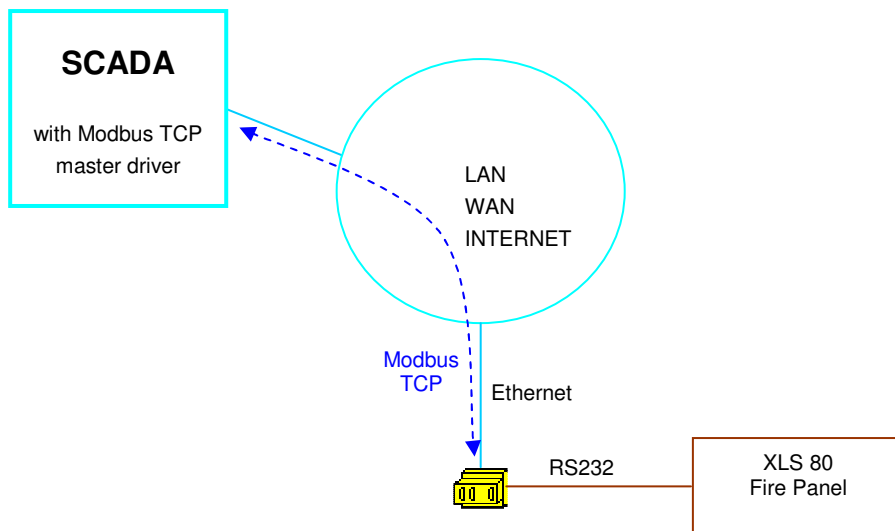

Modbus interface of IntesisBox

Functions supported

- Modbus functions 03 and 04 (*read holding registers* and *read input registers*) can be used to read Modbus registers.
- Modbus function 06 (*Single Multiple Holding Registers*) can be used to write Modbus registers.
- If *poll records* are used to read or write more than one register, it is necessary that the range of addresses requested contains valid addresses, if not the corresponding Modbus error code will be returned.
- Modbus error codes are fully supported, they will be sent whenever a non valid Modbus action or address is required.

Data Formats

The Modbus registers are of 2 bytes (16 bits), its content is expressed always in MSB..LSB.

Modbus RTU

- Baud rate can be selected from 1200, 2400, 4800, 9600, 19200, 38400 and 56700. (Data Bits: 8, parity: none, Stop Bits: 1).
- Modbus slave number can be configured. Physical connection (RS232 or RS485) can also be selected.
- Only the lines RX, TX and GND of the RS232 connector are used (TX/RX+ and TX/RX- for RS485).

Modbus TCP

- The TCP port to use can be configured (by default 502 is used).
- The IP address, subnet mask and default router address to use by IntesisBox can be also configured.

Address Map

The Modbus address map is fix, the register number identifies the element inside the panel.

XLS 80 interface of IntesisBox

General features

- Supports protocols full/duplex (panel main board) and half/duplex (opto-isolated ISO RS232 board, recommended).
- Simple configuration: COM, baud rate, etc.
- Each detector, module and zone is offered in an independent Modbus register.
- Indication of communication error with the panel.
- The value offered per each Modbus register, according to each possible state of the element associated, is configurable. This allows representing different states of the element with a single value in the Modbus register, and even ignoring certain undesired states.
- Commands toward the panel are allowed (i.e. reset, silence... of the panel, and activate/deactivate elements or put them into test mode).

Capacity

- Loops: 1 to 8 (the number used will depend on the panel).
- Detectors: 1 to 99 per loop (the number used will depend on the panel).
- Modules: 1 to 99 per loop (the number used will depend on the panel).
- Zones: 1 to 255 (the number used will depend on the panel).
- 15 general states of the panel in independent Modbus registers.

Configuration tool

LinkBoxMB

- Visual engineering tool, easy of use, for gateway's configuration and supervision compatible with Microsoft Windows operating systems, supplied with the gateway free of charge.
- Multi-window tool allowing to supervise simultaneously the communication activity with both protocols (systems), real time values for all the signals allowing to modify any value (very useful for test purposes), console window showing debug and working status messages, and configuration windows to configure all the gateway's parameters and signals.
- Signals configuration in plain text files (tab separated) for easy and quick configuration using Microsoft Excel (very useful in projects with a lot of points).
- Allows configuring the gateway's parameters and signals while in off-line (not connected to the gateway).
- Connection to the gateway for download the configuration and supervision by using serial COM port of the PC (serial cable supplied with the gateway).
- Allows configuring all the external protocols available for IntesisBox® Modbus Server series.
- Upgrades for this software tool available free of charge whenever a new protocol is added to the IntesisBox® Modbus Server series.
- Multi-project tool allowing having in the engineer's PC the configuration for all the sites with different IntesisBox® Modbus Server series gateways.
- Multi-language tool, all the language-dependent strings are in a plain text file (tab separated) for easy modification or addition of new languages.
- A list of system commands is available to send to the gateway for debugging and adjust purposes (Reset, Date/time consultation/adjust, Firmware version request...).

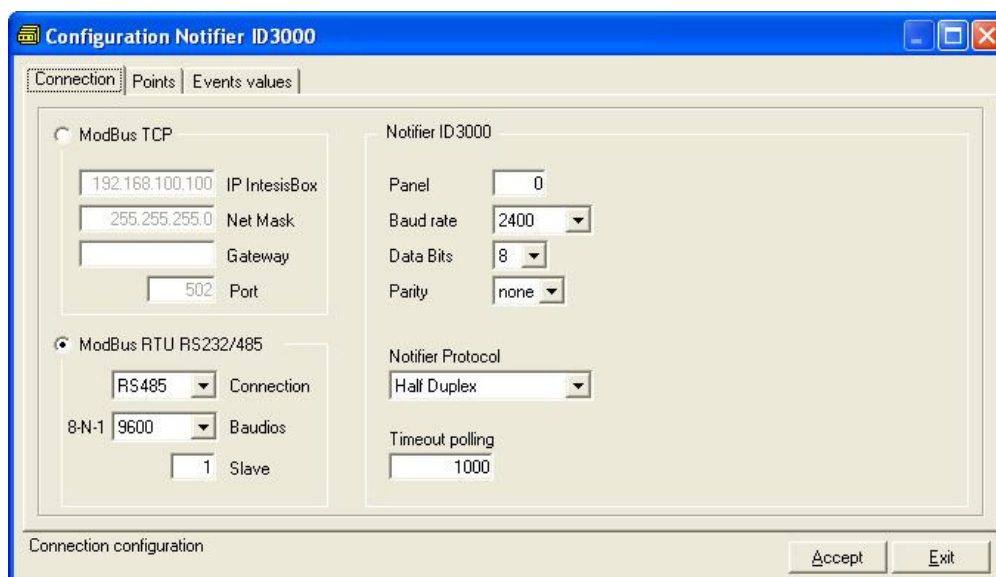

Mechanical & Electrical characteristics



Enclosure	Plastic, type PC (UL 94 V-0). Dimensions: 107mm x 105mm x 58mm.
Color	Light Grey. RAL 7035.
Power	9 to 30Vdc +/-10% 1.4W. 24Vac +/-10% 1.4VA. Plug-in terminal bloc for power connection (2 poles).
Mounting	Wall. DIN rail EN60715 TH35.
XLS 80 port	1 x Serial RS232 (DB9 male DTE).
Modbus RTU ports	1 x Serial RS232 (DB9 male DTE). 1 x Serial RS485 (Plug-in screw terminal block 2 poles).
Modbus TCP port	1 x Ethernet 10BT RJ45.
LED indicators	1 x Power. 2 x Serial port (XLS 80) activity (Tx, Rx). 2 x Serial port (Modbus RTU) activity (Tx, Rx). 2 x Ethernet port link and activity (LNK, ACT).
Console port	RS232. DB9 female connector (DCE).
Configuration	Via console port. ¹
Firmware	Allows upgrades via console port.
Operational temperature	0°C to +70°C
Operational humidity	5% to 95%, non condensing
Protection	IP20 (IEC60529).
RoHS conformity	Compliant with RoHS directive (2002/95/CE).
Certifications	CE

¹ Standard cable DB9male - DB9female 1,8 meters long is supplied with the device for connection to a PC COM port for configuring and monitoring the device. The configuration software, compatible with Windows® operating systems, is also supplied.

Dimensions

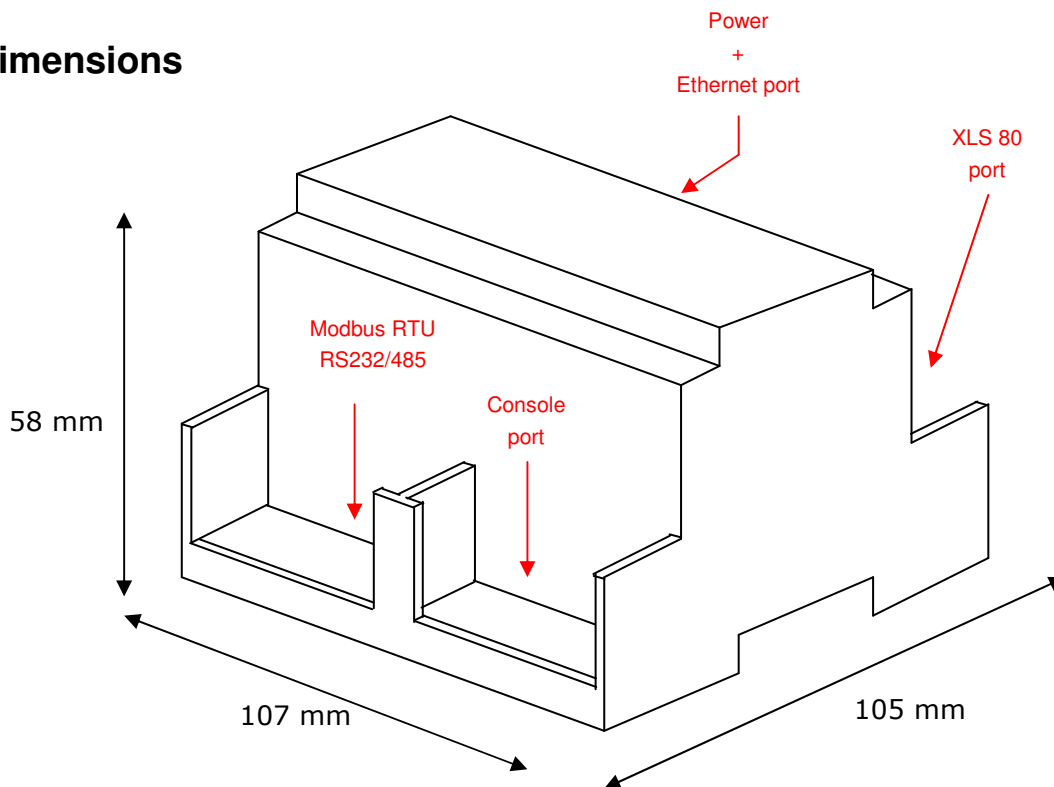

Recommended available space for its installation into a cabinet (wall or DIN rail mounting), with space enough for external connections

